

# HARLO<sup>®</sup> PRODUCTS

MATERIAL HANDLING DIVISION

# HP 6500 HP 8500

**2W & 4W Drive  
6500 / 8500 lb. Capacity  
Powered by John Deere Engine  
Side Shift Masts**

**Agriculture  
Construction  
Turf  
Forestry  
Lumber  
Mining  
Transportation  
Industrial**

## ROUGH TERRAIN FORKLIFTS

No matter what business your're in, this rough terrain forklift

# WILL DO THE JOB.

## HARLO PRODUCTS

P.O. Box 129 | Grandville, MI 49468

P. 616-538-0550 | F. 616-538-1264

[www.harlo.com](http://www.harlo.com) | [sales@harlo.com](mailto:sales@harlo.com)

**POWERED BY**



**JOHN DEERE**



Shown with and without optional cab.

# HARLO HP6500/8500 FORKLIFT SPECIFICATIONS - DEERE ENGINE

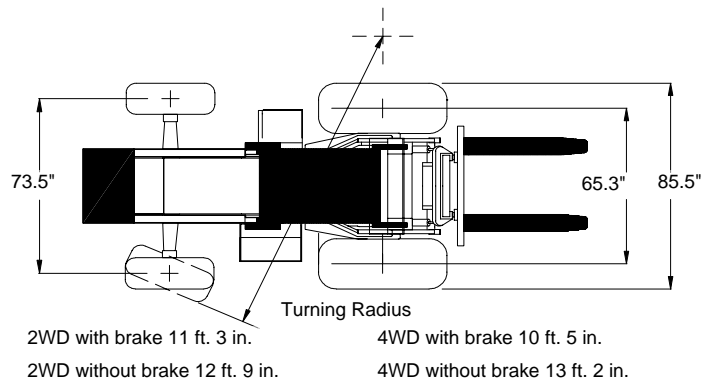
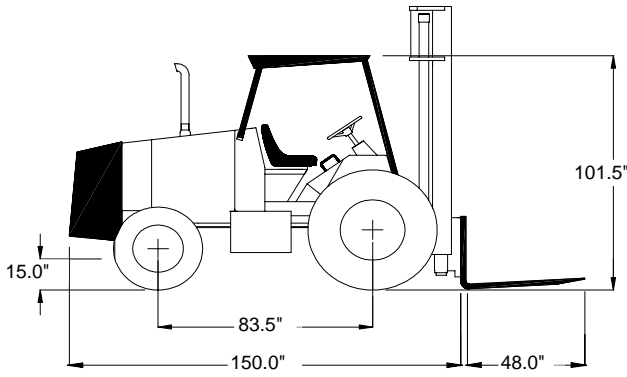

ENGINE		BRAKES						
Make and Model	John Deere 4045DF270	Service Brakes	Hydraulic Multi-wet Disc, Mounted Inboard, Self adjusting and Equalizing					
Type	4 Cycle Diesel	Park Brake	Spring Set- Hydraulic Release. Switch activated, Self Engaging with Engine shutdown					
Aspiration	Naturally	<b>DIMENSIONS</b>						
Number of Cylinders	4	Ht. top Overhead Guard	101.5 in.					
Displacement	275 cu. in.	Wheel Base	83.5 in.					
Bore	4.20 in.	Drive Tread Width	65.3 in.					
Stroke	5.0 in.	Steer Tread Width (2WD)	68.0 in.					
Compression Ratio	17.6:1	Steer Tread Width (4WD)	73.6 in.					
Net Engine Horse Power	80 hp @ 2500	Underclearance	15.0 in.					
Maximum Net Torque	218 ft-lbs @ 1400 rpm	Mast Tilt	30° Forward; 11° Rearward					
Fuel Injection	Rotary Pump, Direct Injection	Overall Width	85.5 in.					
<b>ELECTRICAL SYSTEM</b>		Overall Length (less forks)	150 in					
Voltage	12 Volt	<b>CAPACITIES</b>						
Alternator	65 amp.	Fuel Tank	21.5 U.S. Gal					
Battery Rating	950 CCA, 190 Min. Reserve (79 Ah)	Cooling system	3.9 U.S. Gal					
<b>HYDRAULIC SYSTEM</b>		Engine Oil with Filter	9 qts					
Type	Independent Open Center	Torque Converter and Transmission	20.5 qts					
Pump Type	Gear	Hydraulic System	12.5 U.S. Gal					
Pump Capacity	25 gpm @ 2200 rpm	Powered Steer Axle	1.8 U.S. Gal					
System Pressure	2200 psi	Rigid Drive Axle	4.6 U.S. Gal					
<b>TRANSMISSION</b>		<b>DRIVE AXLE</b>						
Four Speed Transmission, Synchronized in all Gears with Hydraulic Reverser - Shift on the Go		Final Drive	Outboard Planetary					
Torque Converter	Single Stage, Dual Phase with 2.63:1 Stall Ratio	Differential Lock	Hydraulic with Foot Switch					
<b>STEERING SYSTEM</b>		<b>TIRE SIZE</b>						
Type	Priority, Hydrostatic Power Steering	Drive (2WD & 4WD)	19.5 x 24, 10 Ply					
Turns Lock to Lock	3	Steer (2WD)	11L16, 12 Ply					
Axle Oscillation	20°	Steer (4WD)	12.5 x 80-18, 10 Ply					
<b>MAST OPTIONS</b>								
Capacity	Lift Height	Overall Lowered	Overall Extended	Carriage Width	2WD Weight	4WD Weight	Free Lift	Capacity @ 24" Load Center
6,500 lbs.	15 ft. 2 Stg.	125 in.	210 in.	60, 72, or 84 in.	12,790 lb.	13,126 lb.	None	6,500# to 15'
	22 ft. 3 Stg.	125 in.	300 in.	60, 72 or 84 in.	13,410 lb.	13,700 lb.	None	6,500# to 12', 4,500# to 15', 2,500# to 22'
	28 ft. 3 Stg.	146 in.	372 in.	60 in.	13,709 lb.	13,896 lb.	None	6,500# to 12', 4,500# to 15', 2,500# to 22', 1,000# to 28'
8,500 lbs.	15 ft. 2 Stg.	125 in.	212 in.	60, 72, or 84 in.	15,160 lb.	15,346 lb.	None	8,500# to 15 ft.
	16 ft. 3 Stg.	100 in.	228 in.	60, 72, or 84 in.	15,316 lb.	15,392 lb.	None	8,500# to 12', 6,500# to 16'
	22 ft. 3 Stg.	125 in.	300 in.	60, 72 or 84 in.	16,766 lb.	16,842 lb.	None	8,500# to 12', 6,500# to 15', 2,500# to 22'
6,500 lbs Free Lift	20 ft. 3 Stg.	117 in.	266 in.	60, 72 or 84 in.	13,508 lb.	13,798 lb.	80 in.	6,500# to 12', 4,500# to 15', 2,500# to 20'

Contact Harlo for special masts.

Rev (2/08)